



Centrífugo

Mando Directo
"RSH"



Centrífugos Mando Directo "RSH"

Ventiladores centrífugos, de mando directo y simple aspiración, modelo RSH, de alto rendimiento. Cuentan con rodetes de 11 palas inclinadas hacia atrás, que permiten un alto rendimiento y bajo nivel sonoro.



Esta serie esta disponible en 10 tamaños, desde 250 a 800 mm (Diámetros nominales de los rodetes) El dimencionamiento omotetico y las dimensiones nominales están de acuerdo a normas.



Centrífugos Mando Directo "RSH"

CARACTERÍSTICAS CONSTRUCTIVAS

VENTILADOR

- Envolvente y estructura: En chapa de acero galvanizado
- Rodete: En acero carbono, soldado, tratado y pintado.
- Temp. de trabajo -40° $+300^{\circ}$
- Temp. de calculo: 40°C
- Altitud: 150 mt sobre nivel del mar
- Densidad del aire: 1.10558 kg/mt^3
- Otros datos técnicos: A pedido, sin costo

MOTOR

- Eficiencia Estándar
- Protección: IP55
- Clase F
- Servicio continuo(SI)
- Temperatura ambiente: 40°C





Centrífugos Mando Directo "RSH"

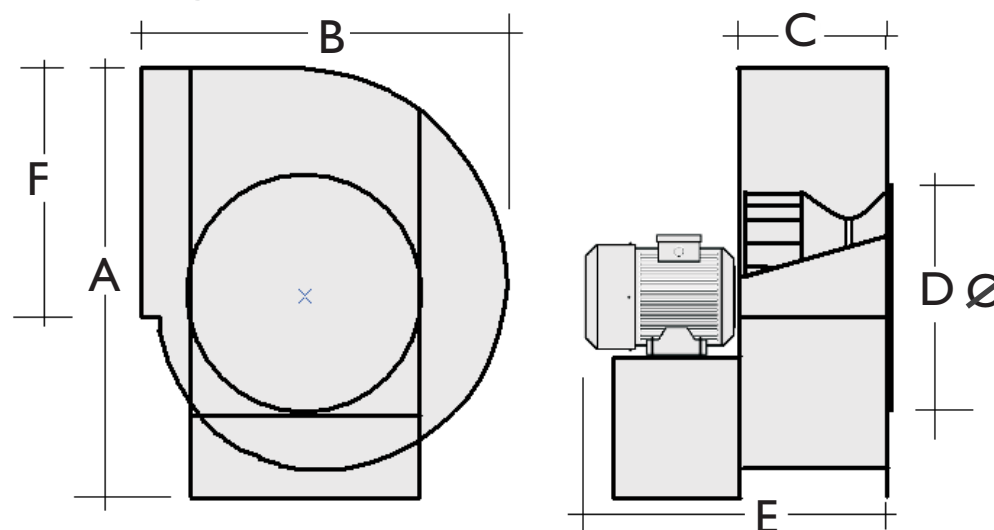

DIMENSIONES APROXIMADAS

Modelo	A m/m	B m/m	C m/m	D m/m	E m/m	F m/m
RSH250-2P	448	406	160	250	378	277
RSH250-4P	448	406	160	250	378	277
RSH315-2P	568	540	200	315	479	351
RSH315-4P	568	540	200	315	436	351
RSH355-2P	640	602	230	355	546	396



DIMENSIONES APROXIMADAS

Centrífugos Mando Directo "RSH"

Modelo	A m/m	B m/m	C m/m	D m/m	E m/m	F m/m
RSH355-4P	640	602	230	355	466	396
RSH355-6P	640	602	230	355	484	396
RSH400-2P	717	689	250	400	622	438
RSH400-4P	717	689	250	400	504	438
RSH400-6P	717	689	250	400	486	438
RSH450-2P	807	746	285	450	773	493
RSH450-4P	807	746	285	450	564	493
RSH450-6P	807	746	285	450	539	493
RSH500-2P	906	831	310	500	967	553
RSH500-4P	906	831	310	500	643	553
RSH500-6P	906	831	310	500	626	553



Centrífugos Mando Directo "RSH"

DIMENSIONES APROXIMADAS

Modelo	A m/m	B m/m	C m/m	D m/m	E m/m	F m/m
RSH560-4P	1004	916	350	560	722	621
RSH560-6P	1004	916	350	560	683	621
RSH630-4P	1130	1023	400	630	888	690
RSH630-6P	1130	1023	400	630	772	690
RSH710-4P	1202	1075	460	710	992	752
RSH710-6P	1202	1075	460	710	870	752
RSH800-6P	1435	1338	520	800	1112	876



CARACTERÍSTICAS TÉCNICAS

Centrífugos Mando Directo "RSH"

Modelo	VELOCIDAD RPM	Corriente Nominal en 380 V (A)	Consumo HP	Potencia HP	Caudal (m ³ /h)	Nivel Sonoro dB(A)
RSH250-2P	2.780	1,31	0,50	0,75	2.000	81
RSH250-4P	1.390	1,09	0,16	0,50	990	60
RSH315-2P	2.840	4,85	2,30	3,00	4.627	95
RSH315-4P	1.420	1,43	0,25	0,75	2.429	77
RSH355-2P	2.890	6,14	3,30	4,00	6.966	100
RSH355-4P	1.415	1,82	0,50	1,00	3.500	81
RSH355-6P	940	1,76	0,25	0,75	2.400	71
RSH400-2P	2.925	10,90	4,60	7,50	9.760	100
RSH400-4P	1.440	2,75	0,80	1,50	4.950	82
RSH400-6P	940	1,76	0,35	0,75	3.250	71
RSH450-2P	2.950	21,90	9,80	15,00	13.500	105



Centrífugos Mando Directo "RSH"

CARACTERÍSTICAS TÉCNICAS

Modelo	VELOCIDAD RPM	Corriente Nominal en 380 V (A)	Consumo HP	Potencia HP	Caudal (m ³ /h)	Nivel Sonoro dB(A)
RSH450-4P	1.420	3,37	1,40	2,00	7.000	86
RSH450-6P	940	2,19	0,50	1,00	4.540	75
RSH500-2P	2.945	35,60	22,00	25,00	21.000	100
RSH500-4P	1.420	6,42	2,80	4,00	10.200	89
RSH500-6P	940	3,88	0,84	2,00	6.650	78
RSH560-4P	1.430	11,10	5,70	7,50	14.000	94
RSH560-6P	930	5,67	2,00	3,00	9.200	82



Centrífugos Mando Directo "RSH"

CARACTERÍSTICAS TÉCNICAS

Modelo	VELOCIDAD RPM	Corriente Nominal en 380 V (A)	Consumo HP	Potencia HP	Caudal (m ³ /h)	Nivel Sonoro dB(A)
RSH630-4P	1.470	22,10	8,20	15,00	20.200	96
RSH630-6P	960	9,51	3,20	4,00	13.300	85
RSH710-4P	1.460	30,30	16,00	20,00	30.000	101
RSH710-6P	965	13,00	4,20	7,50	19.500	90
RSH800-6P	970	15,80	8,20	15,00	27.000	92



ORIENTACIÓN

Al ordenar su ventilador, confirmar la orientación deseada

Centrífugos Mando Directo "RSH"

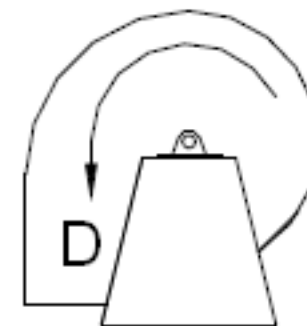
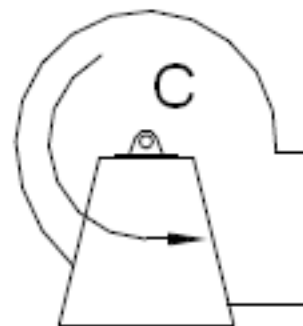
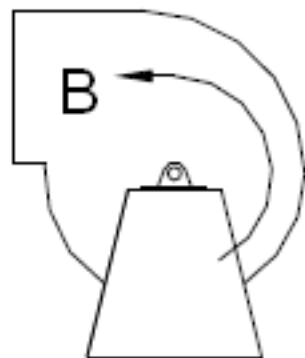
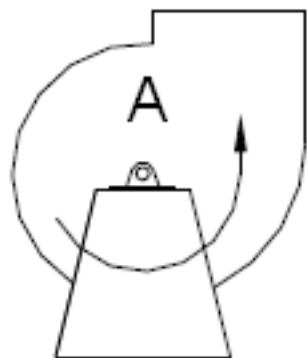

Vistas desde el lado del Motor y/o Ejes de Mando c/ Poleas

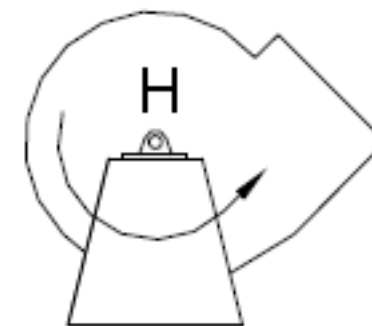
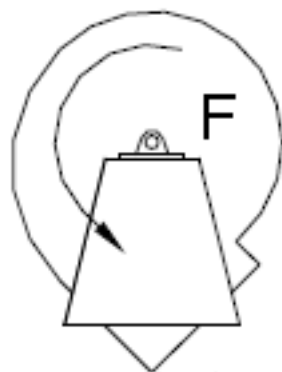
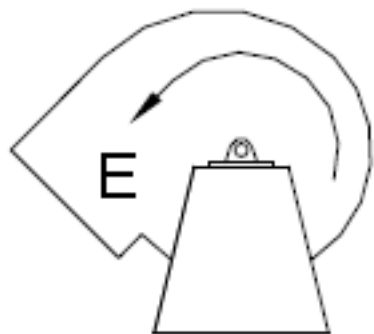



Centrífugos Mando Directo "RSH"

CURVAS DE COMPORTAMIENTO

Modelo

RSH250-2P

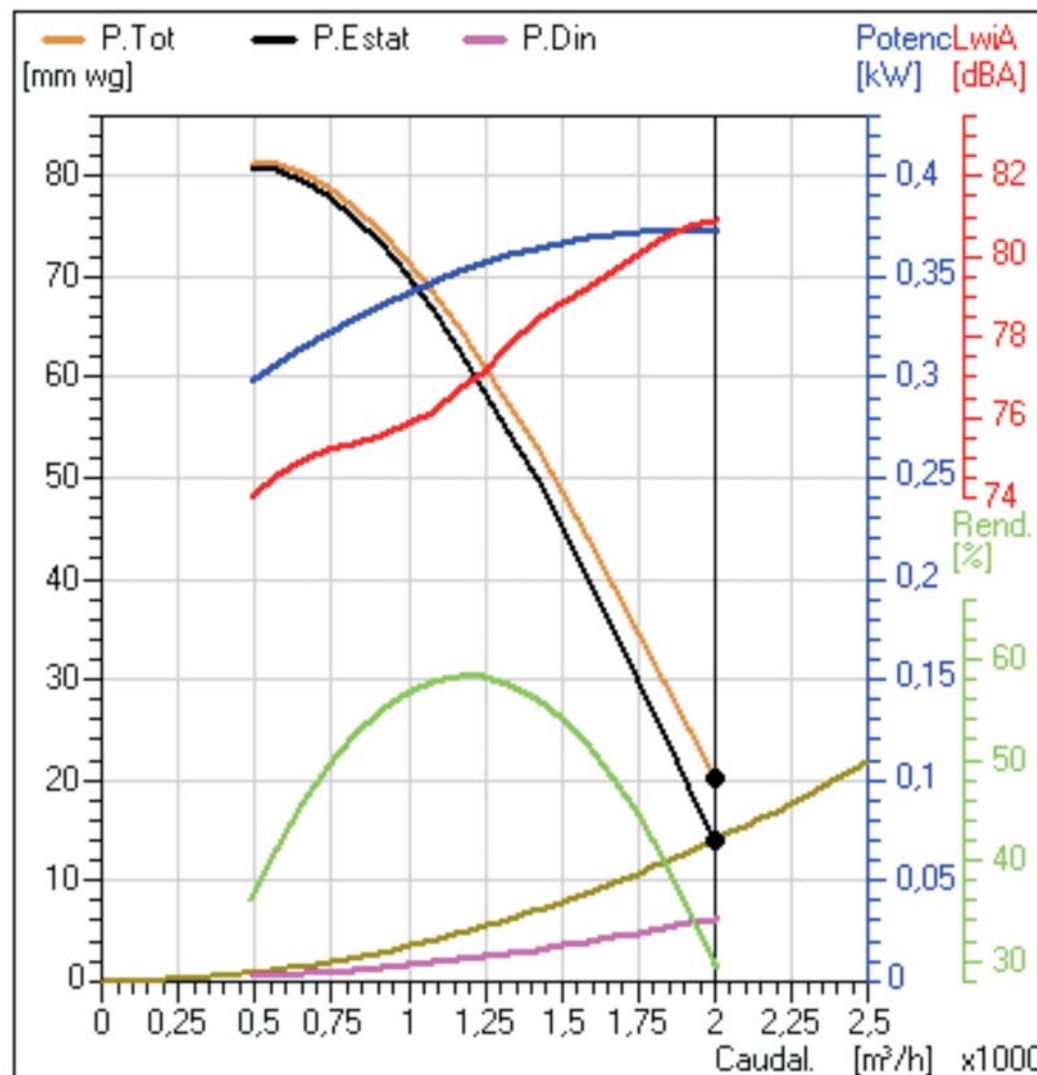



Centrífugos Mando Directo "RSH"

CURVAS DE COMPORTAMIENTO

Modelo

RSH250-4P

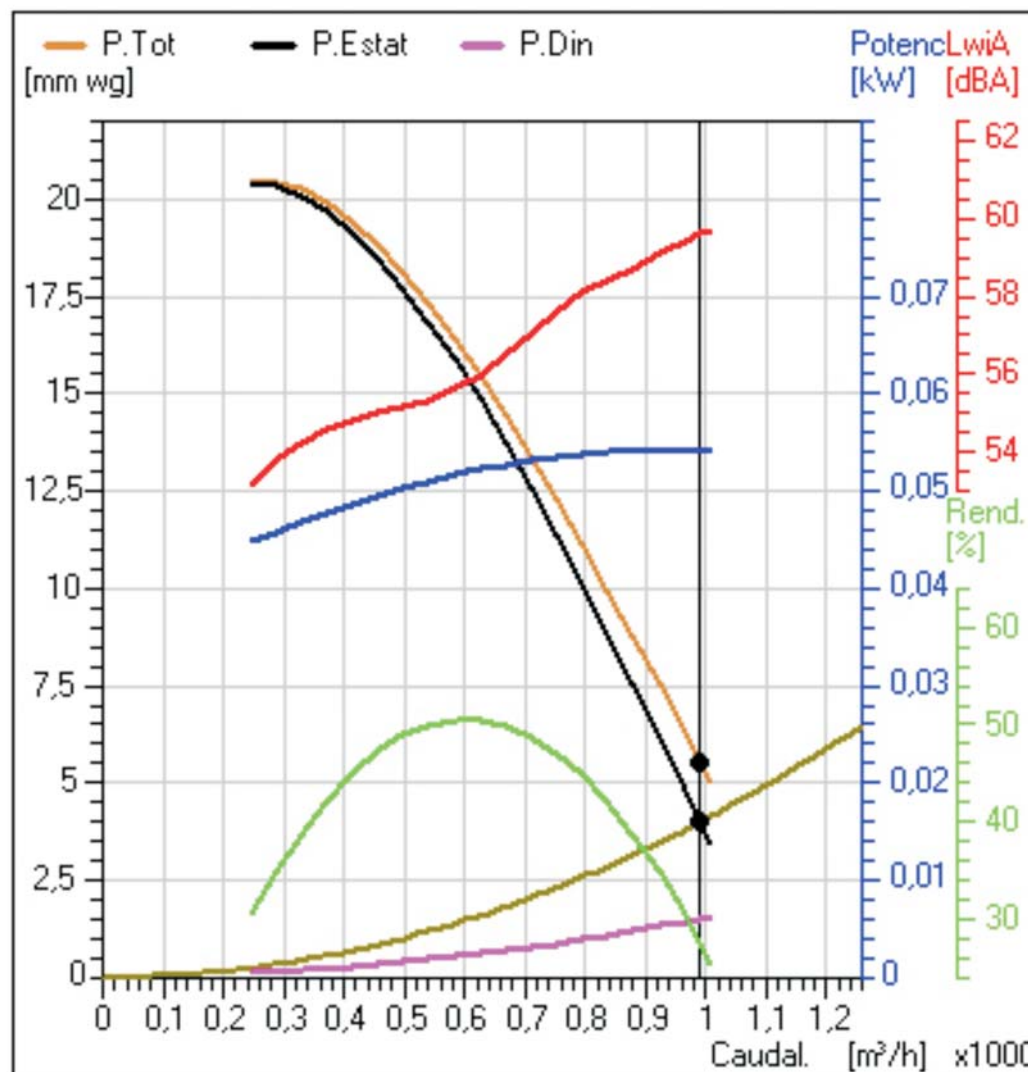



Centrífugos Mando Directo "RSH"

CURVAS DE COMPORTAMIENTO

Modelo

RSH315-2P

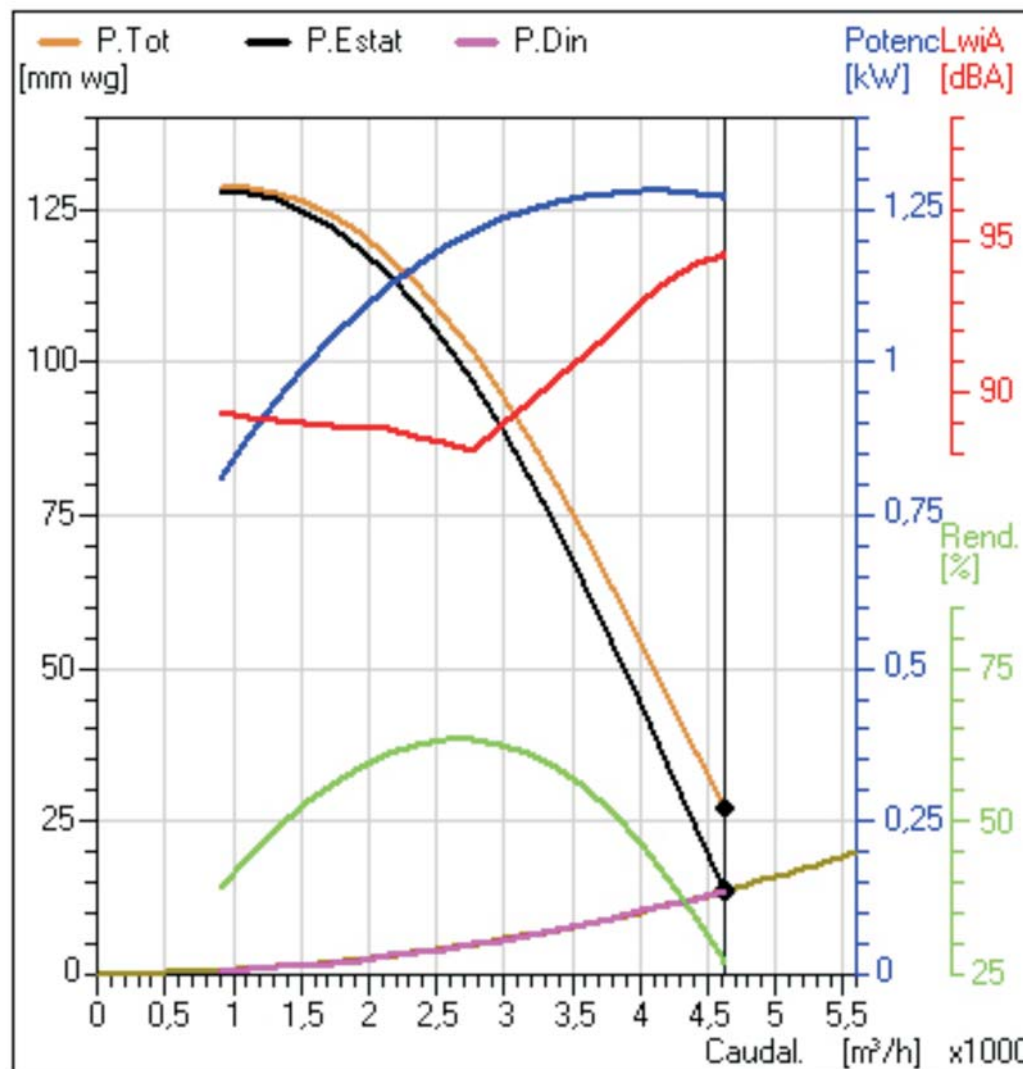



Centrífugos Mando Directo "RSH"

CURVAS DE COMPORTAMIENTO

Modelo

RSH315-4P

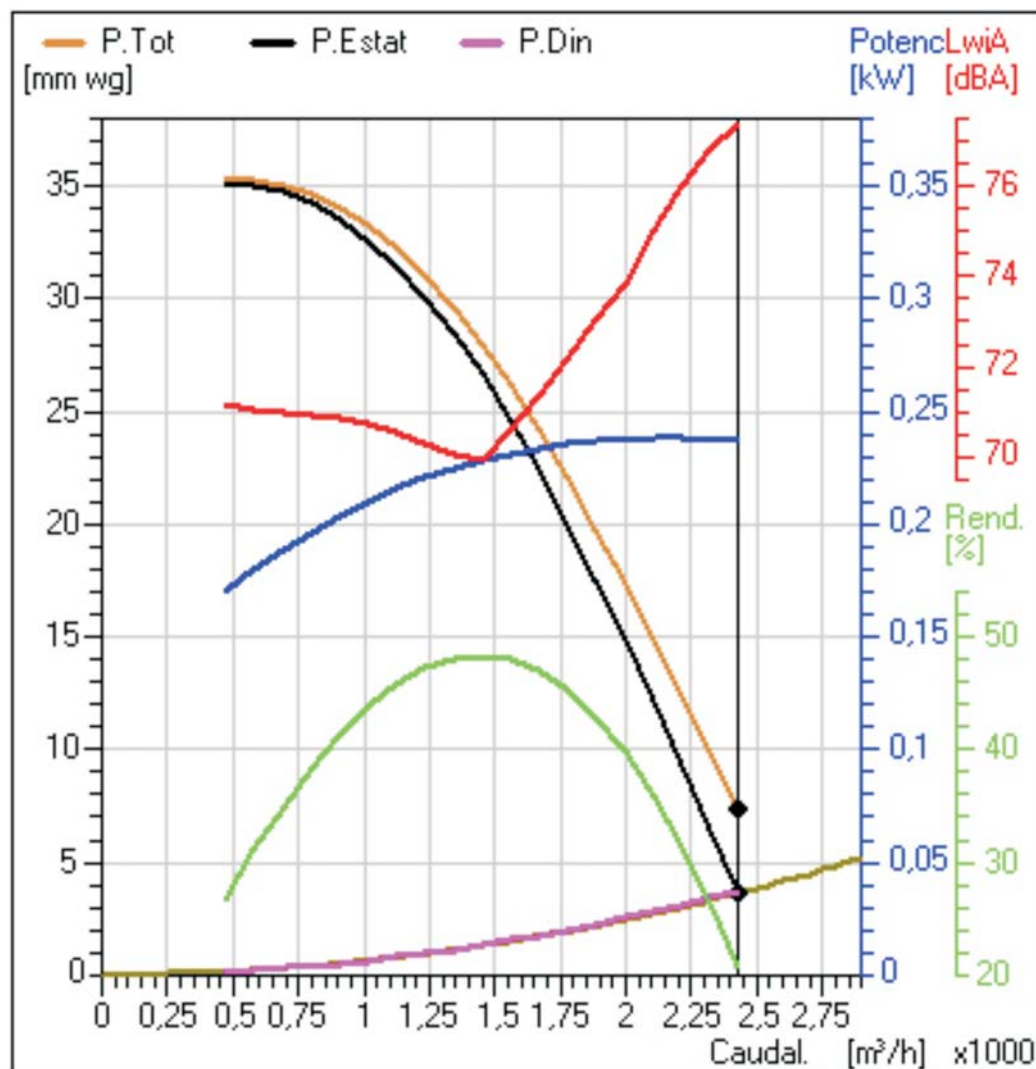



Centrífugos Mando Directo "RSH"

CURVAS DE COMPORTAMIENTO

Modelo

RSH355-2P

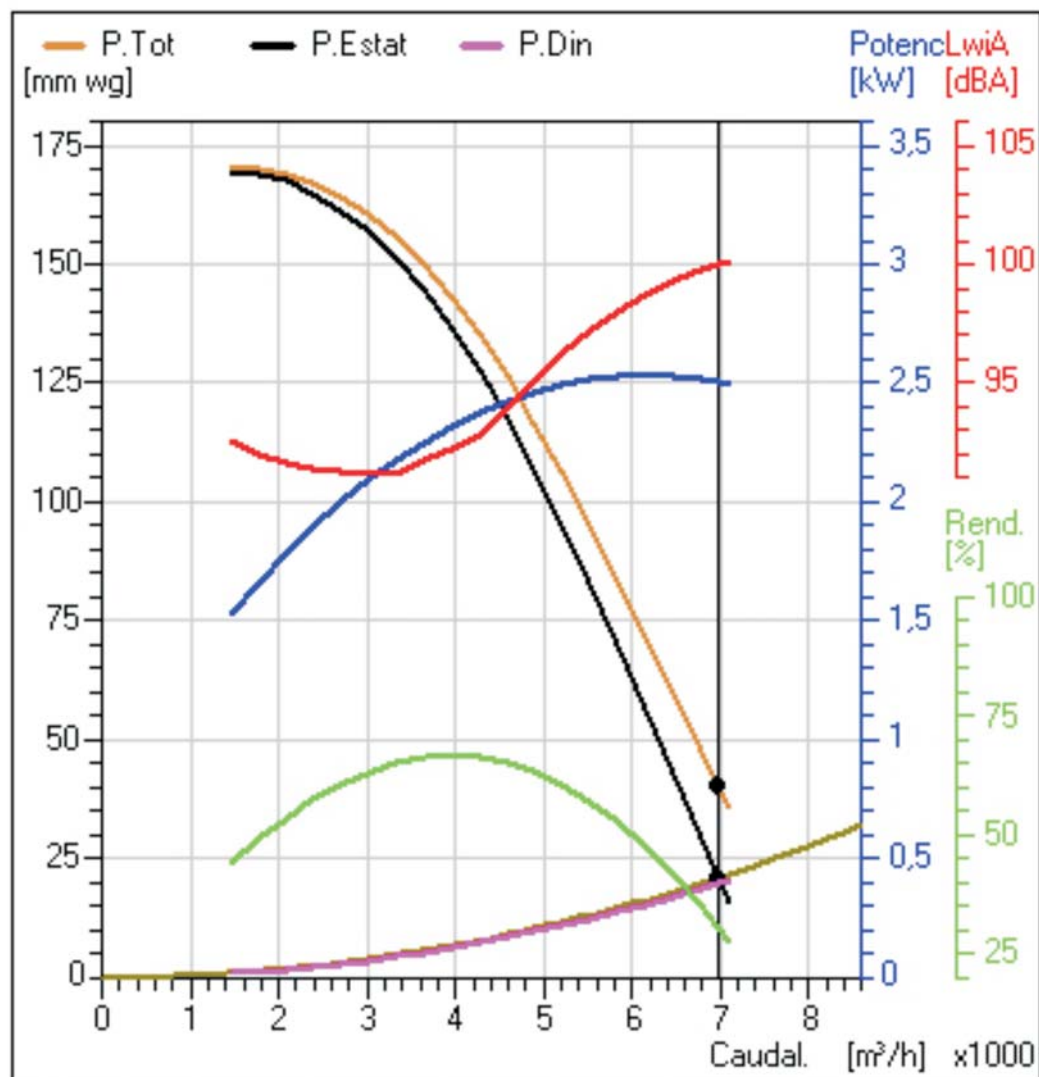



Centrífugos Mando Directo "RSH"

CURVAS DE COMPORTAMIENTO

Modelo

RSH355-4P

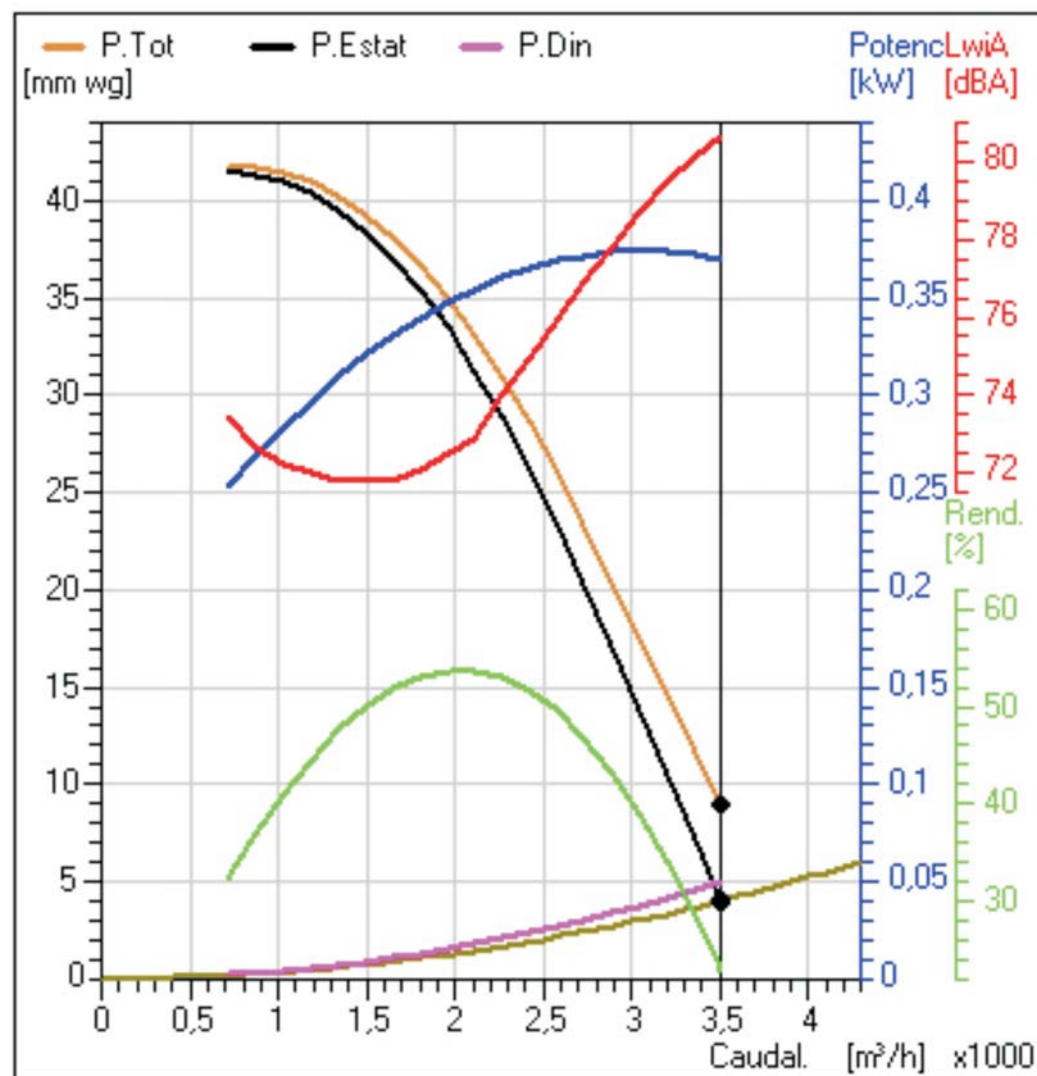



Centrífugos Mando Directo "RSH"

CURVAS DE COMPORTAMIENTO

Modelo

RSH355-6P

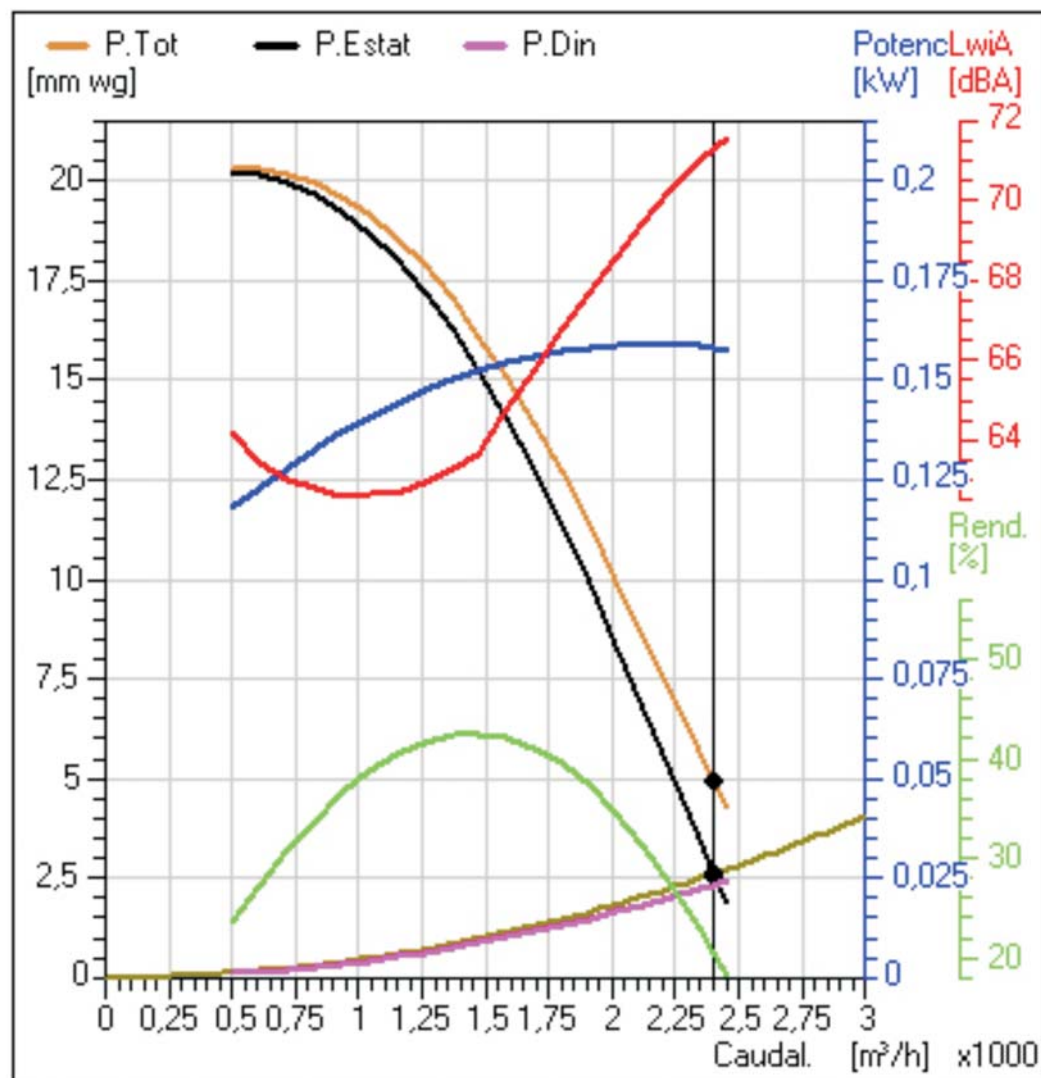



Centrífugos Mando Directo "RSH"

CURVAS DE COMPORTAMIENTO

Modelo

RSH400-2P

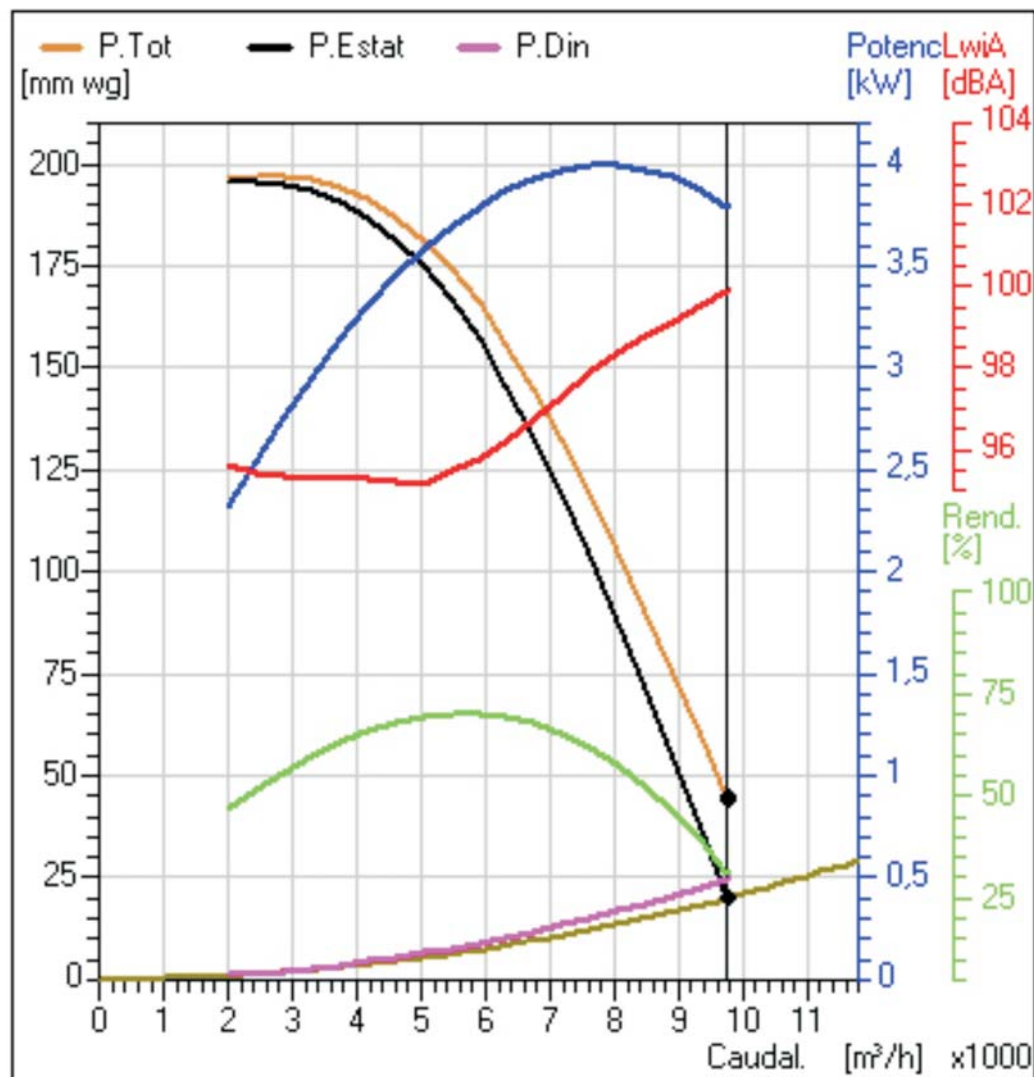



Centrífugos Mando Directo "RSH"

CURVAS DE COMPORTAMIENTO

Modelo

RSH400-4P

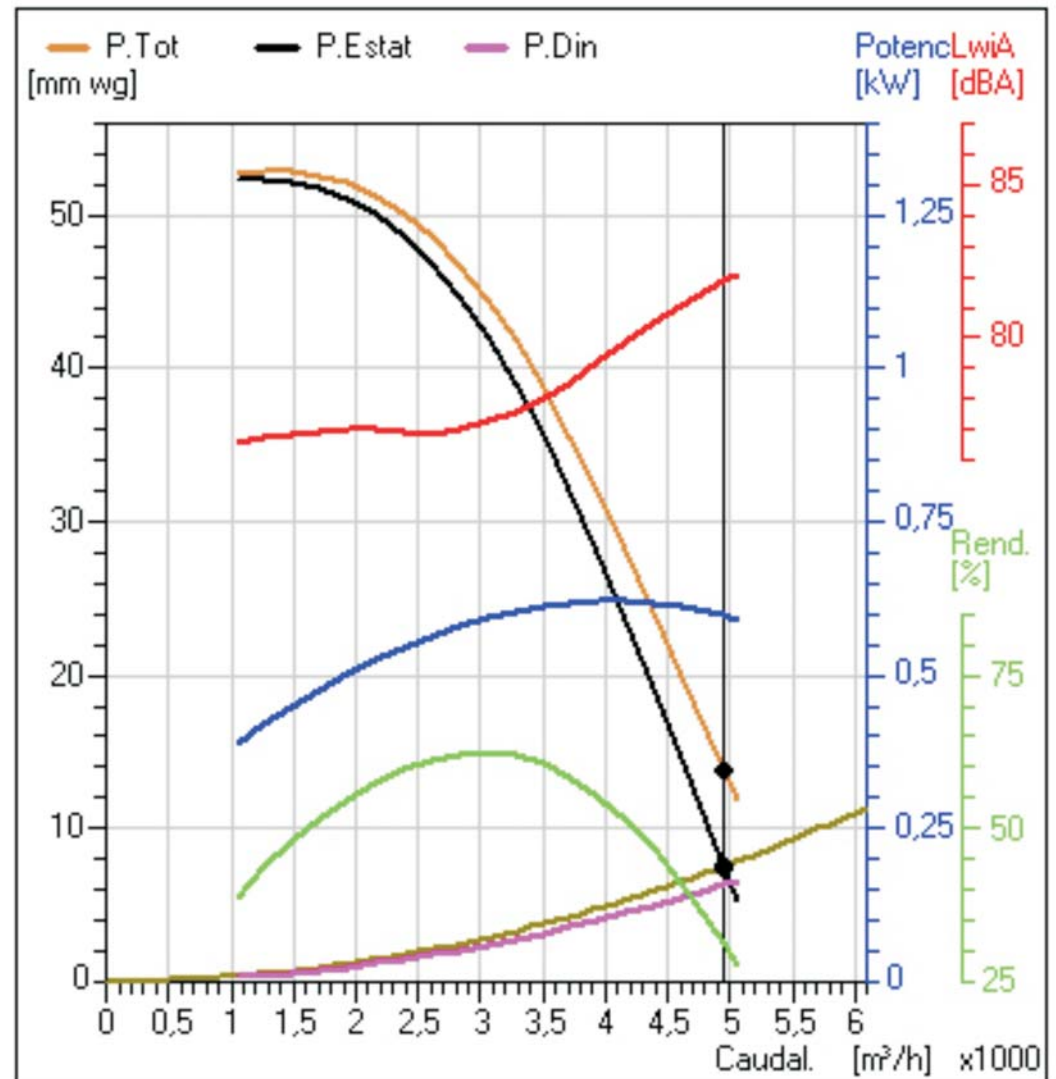



Centrífugos Mando Directo "RSH"

CURVAS DE COMPORTAMIENTO

Modelo

RSH400-6P

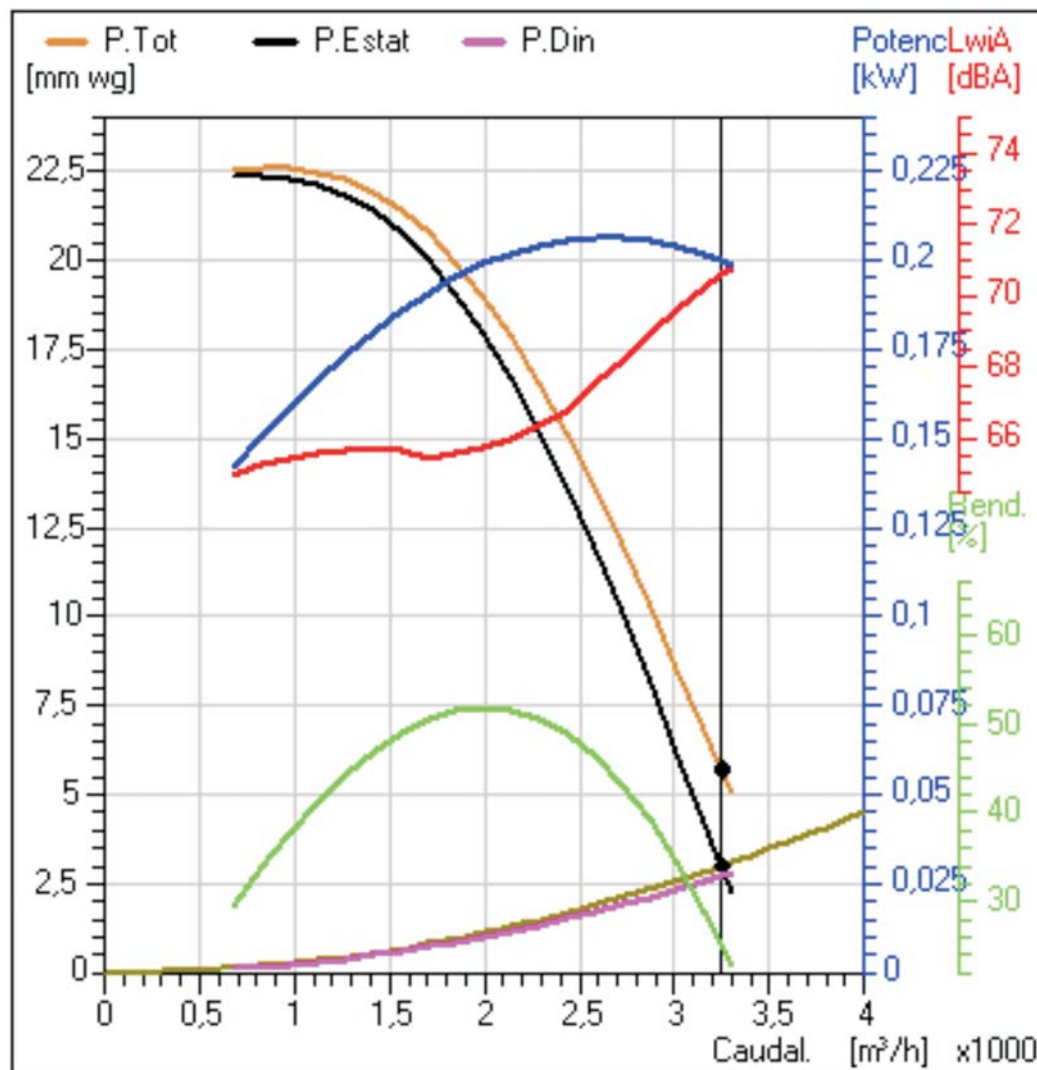



Centrífugos Mando Directo "RSH"

CURVAS DE COMPORTAMIENTO

Modelo

RSH450-2P

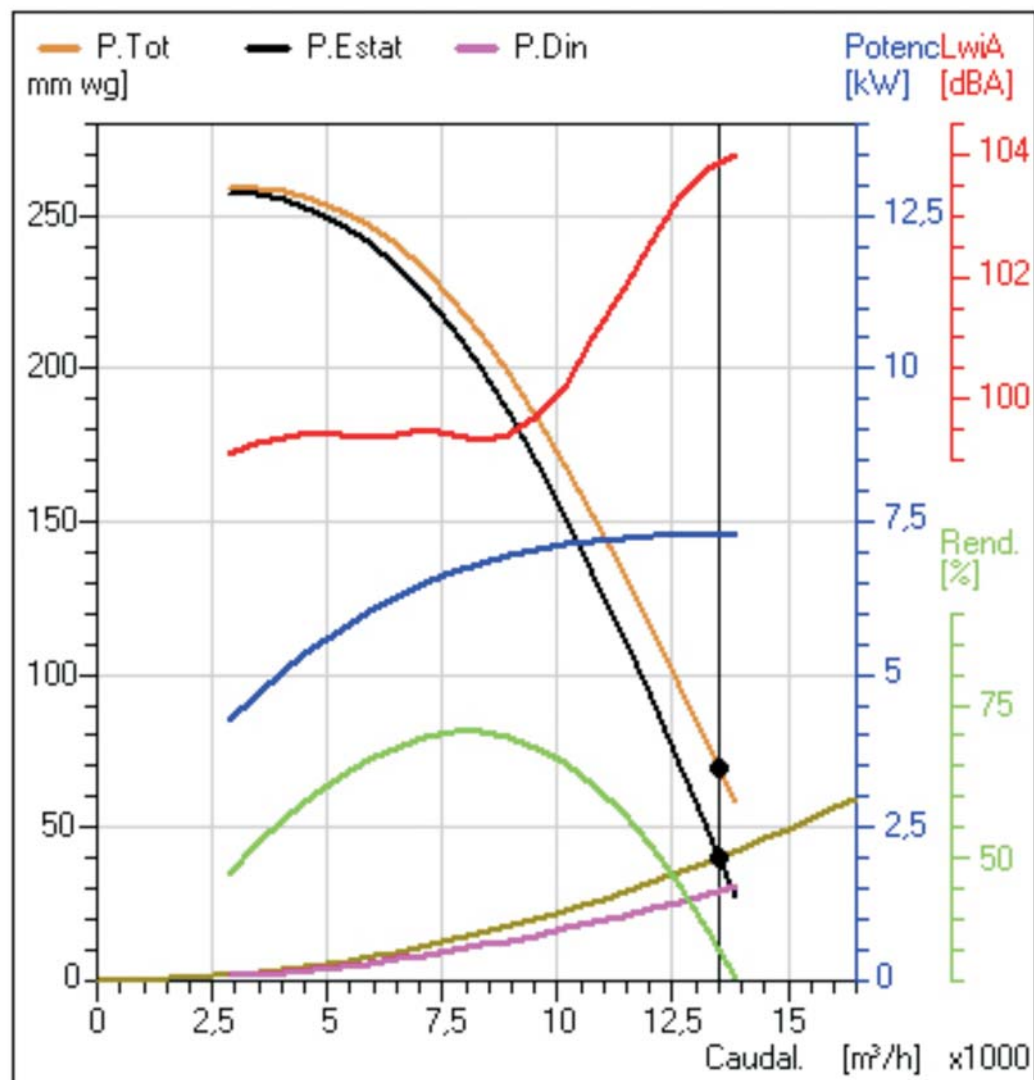



Centrífugos Mando Directo "RSH"

CURVAS DE COMPORTAMIENTO

Modelo

RSH450-4P

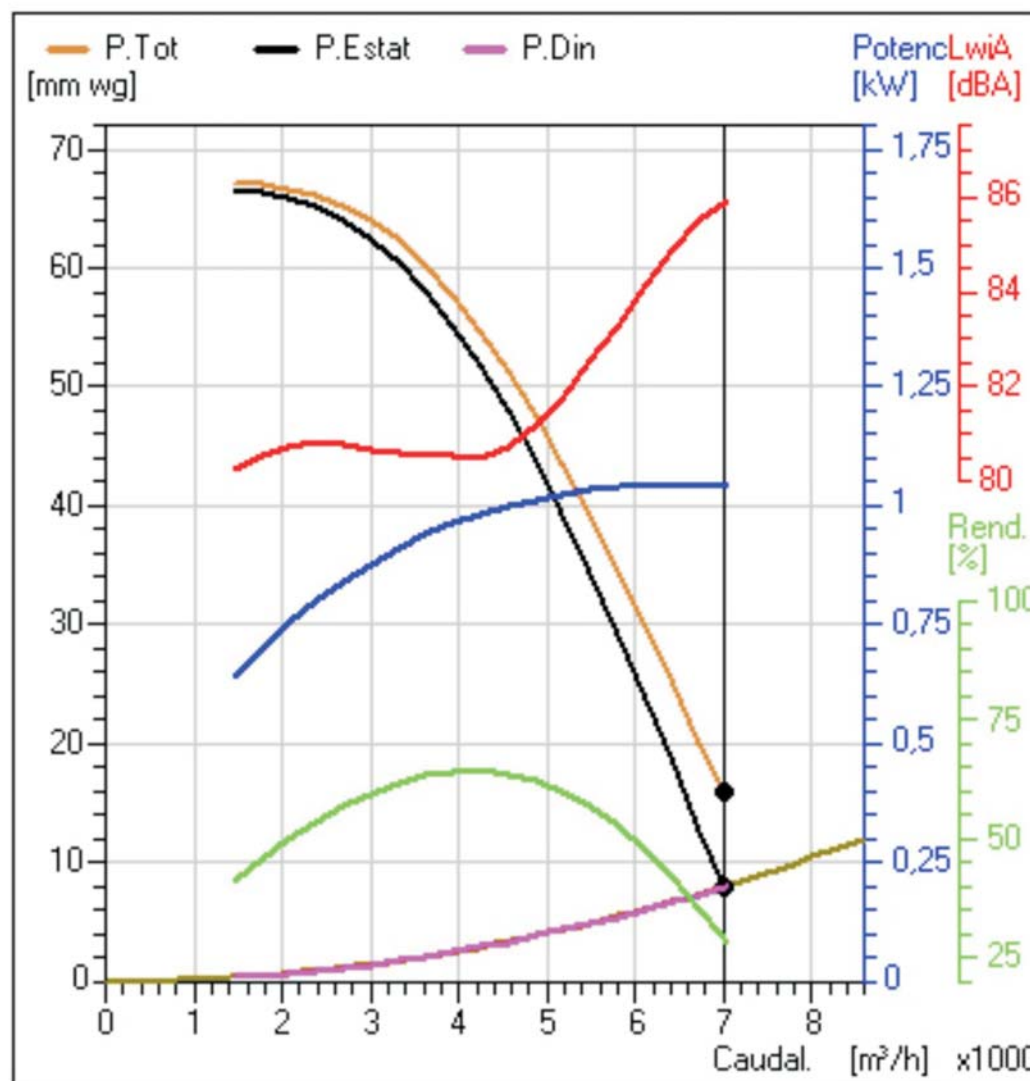



Centrífugos Mando Directo "RSH"

CURVAS DE COMPORTAMIENTO

Modelo

RSH450-6P

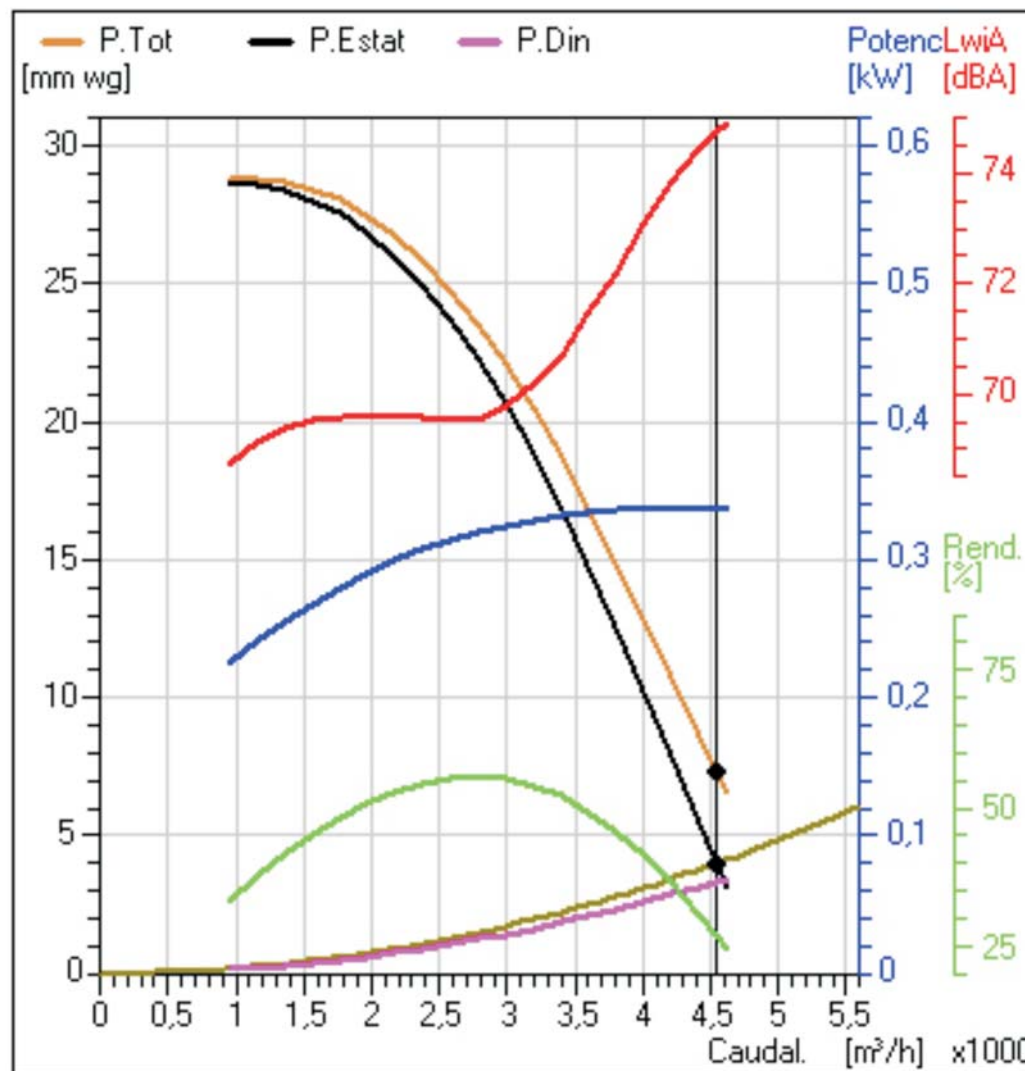



Centrífugos Mando Directo "RSH"

CURVAS DE COMPORTAMIENTO

Modelo

RSH500-2P

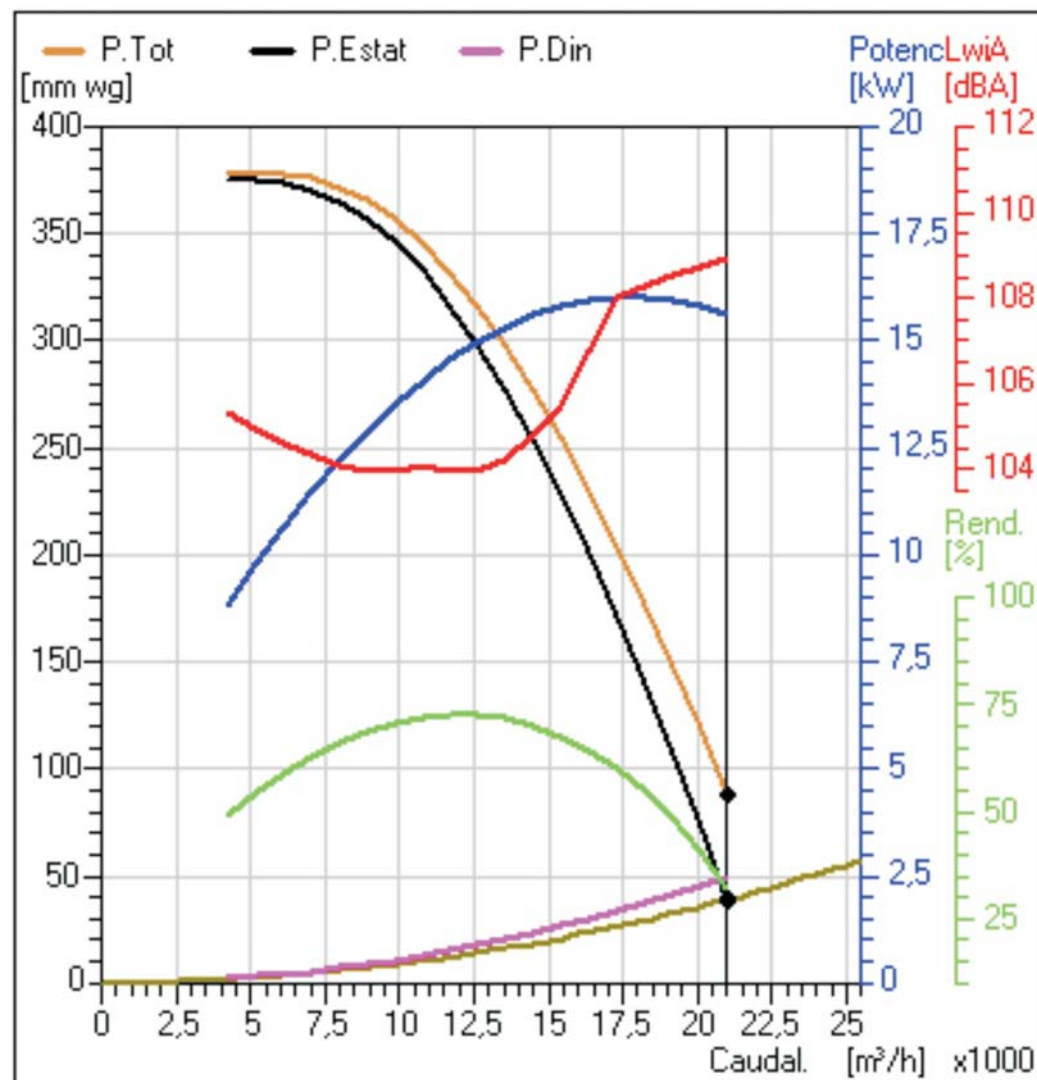



Centrífugos Mando Directo "RSH"

CURVAS DE COMPORTAMIENTO

Modelo

RSH500-4P

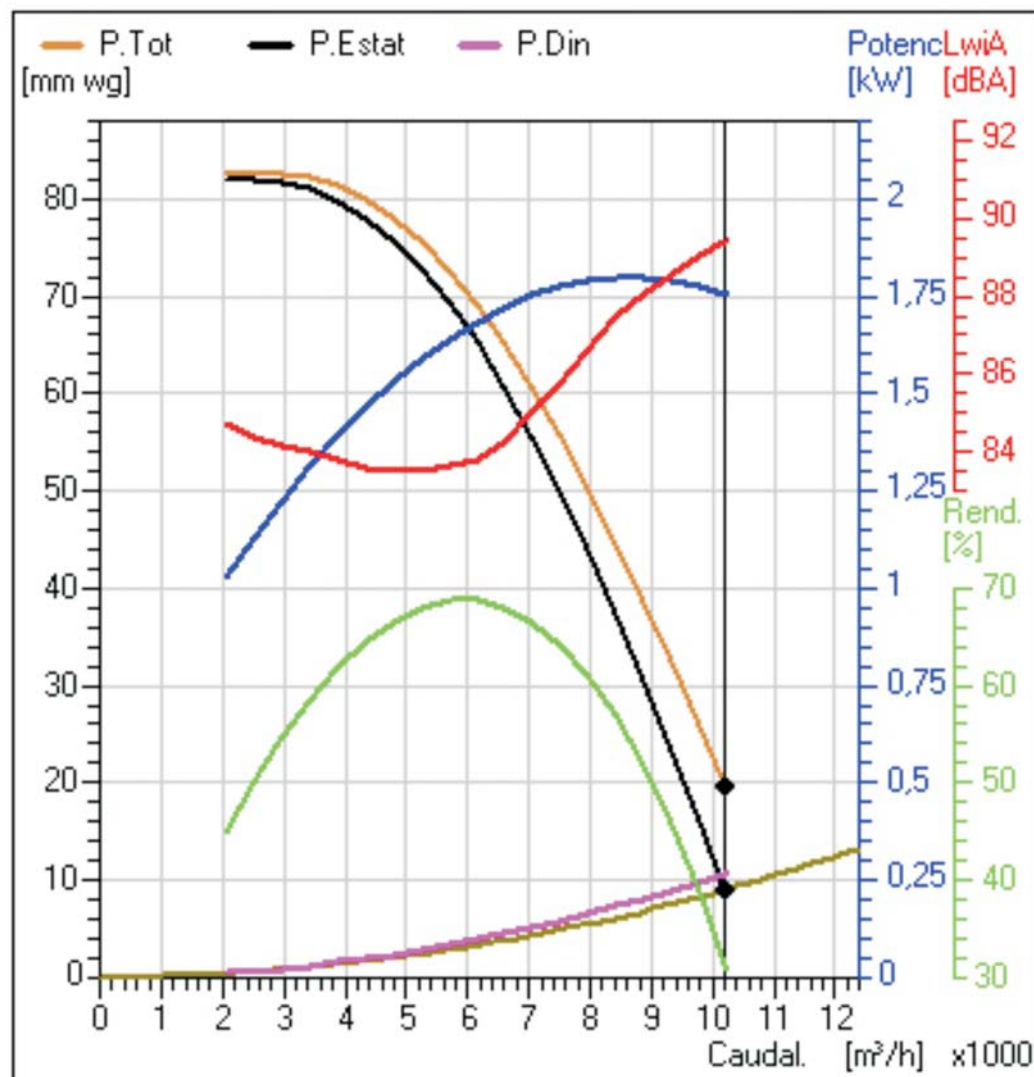



Centrífugos Mando Directo "RSH"

CURVAS DE COMPORTAMIENTO

Modelo

RSH500-6P

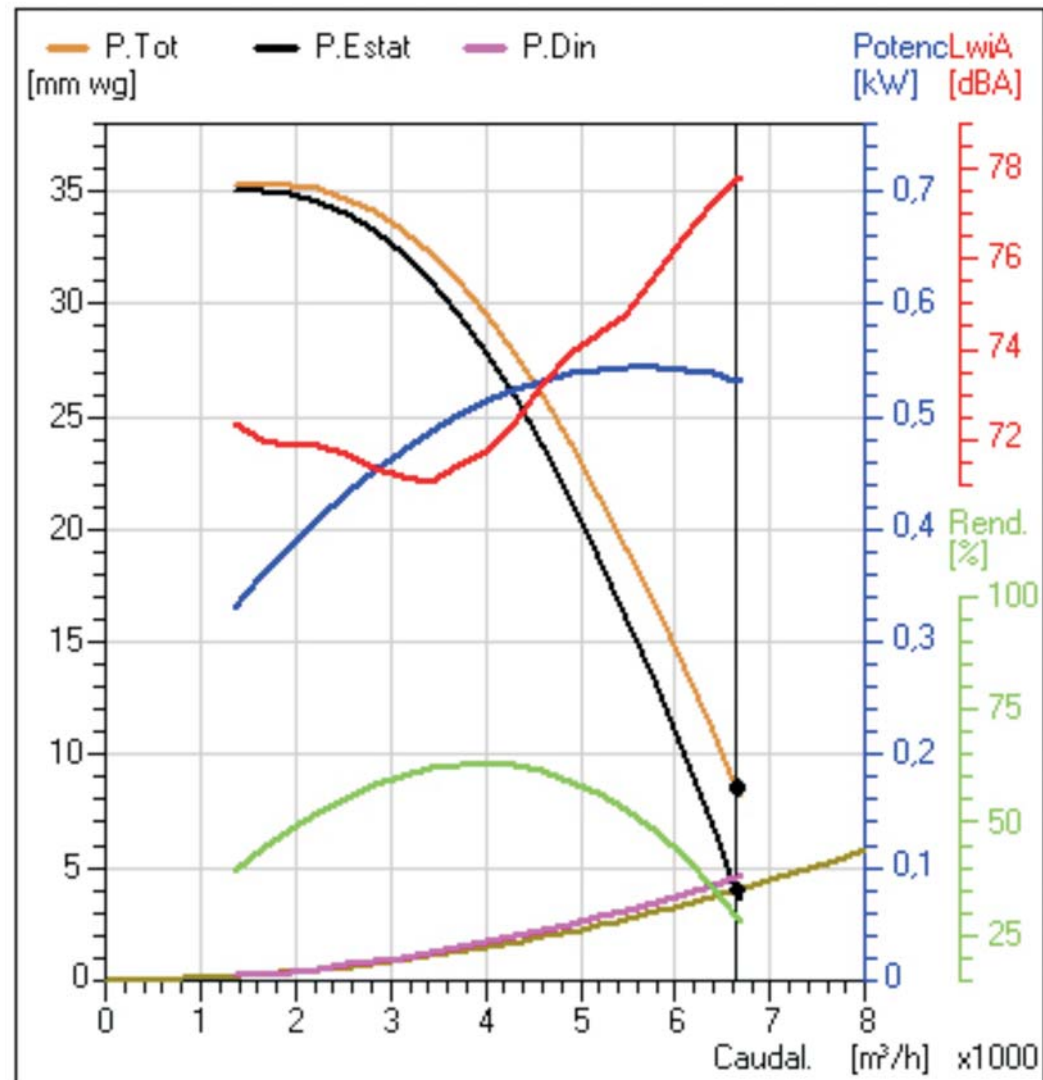



Centrífugos Mando Directo "RSH"

CURVAS DE COMPORTAMIENTO

Modelo

RSH560-4P

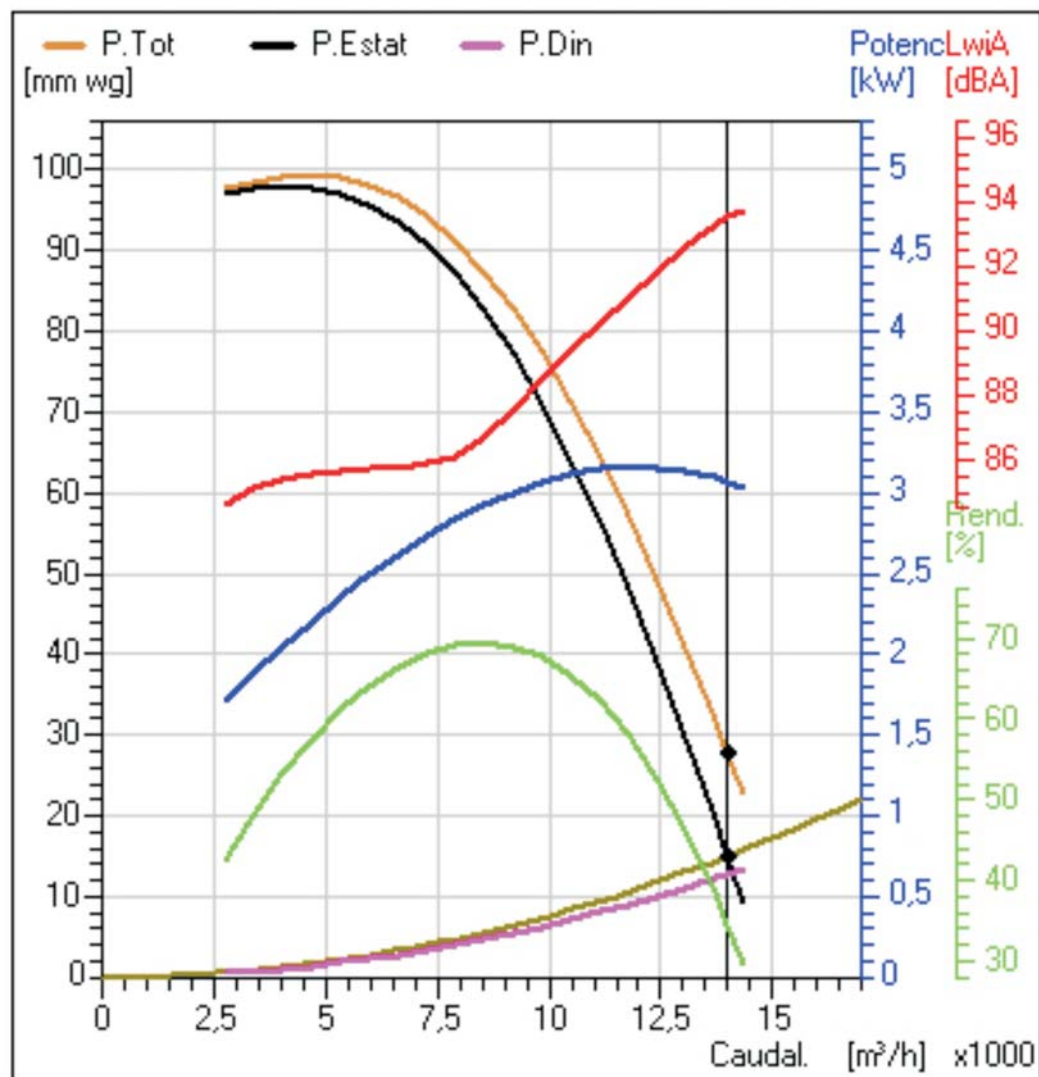



Centrífugos Mando Directo "RSH"

CURVAS DE COMPORTAMIENTO

Modelo

RSH560-6P

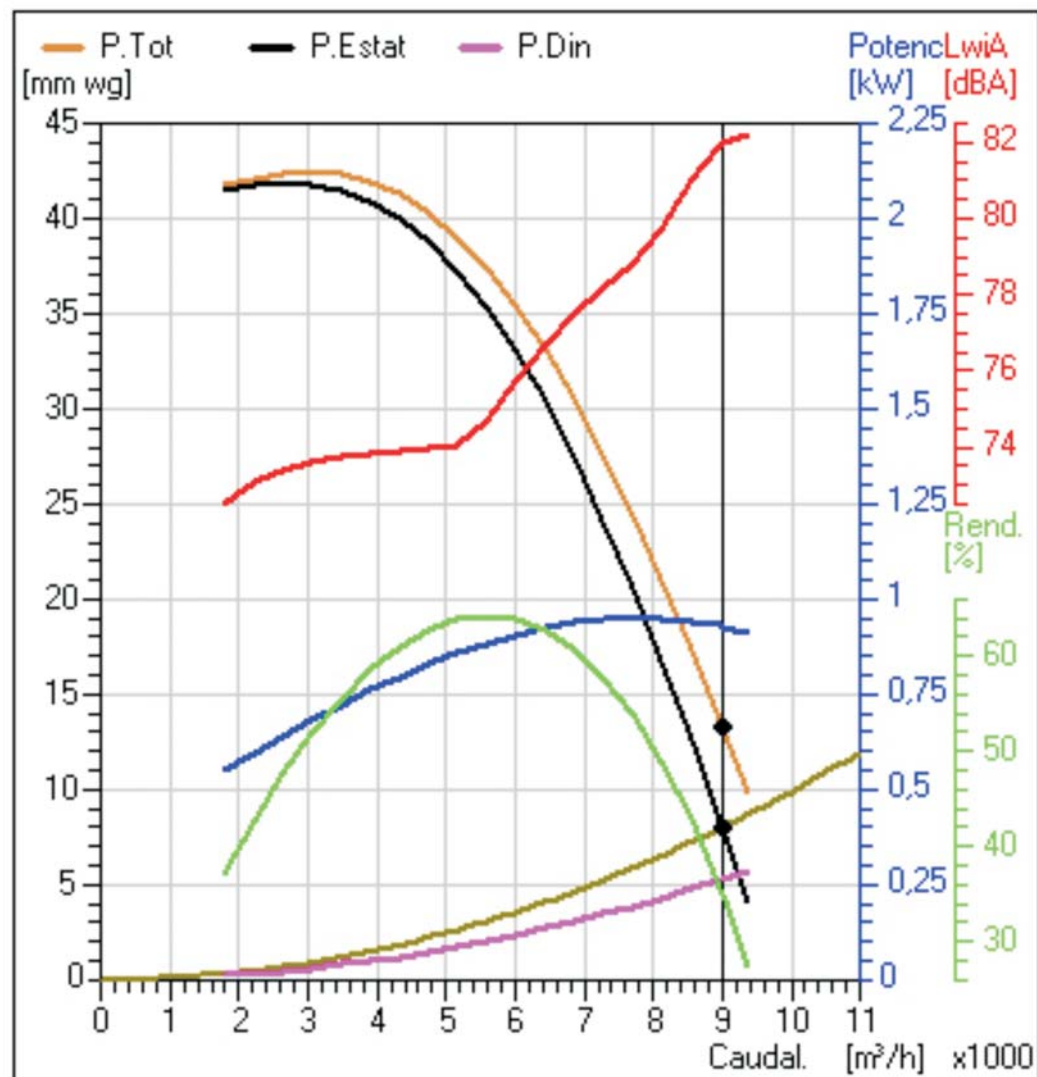



Centrífugos Mando Directo "RSH"

CURVAS DE COMPORTAMIENTO

Modelo

RSH630-4P

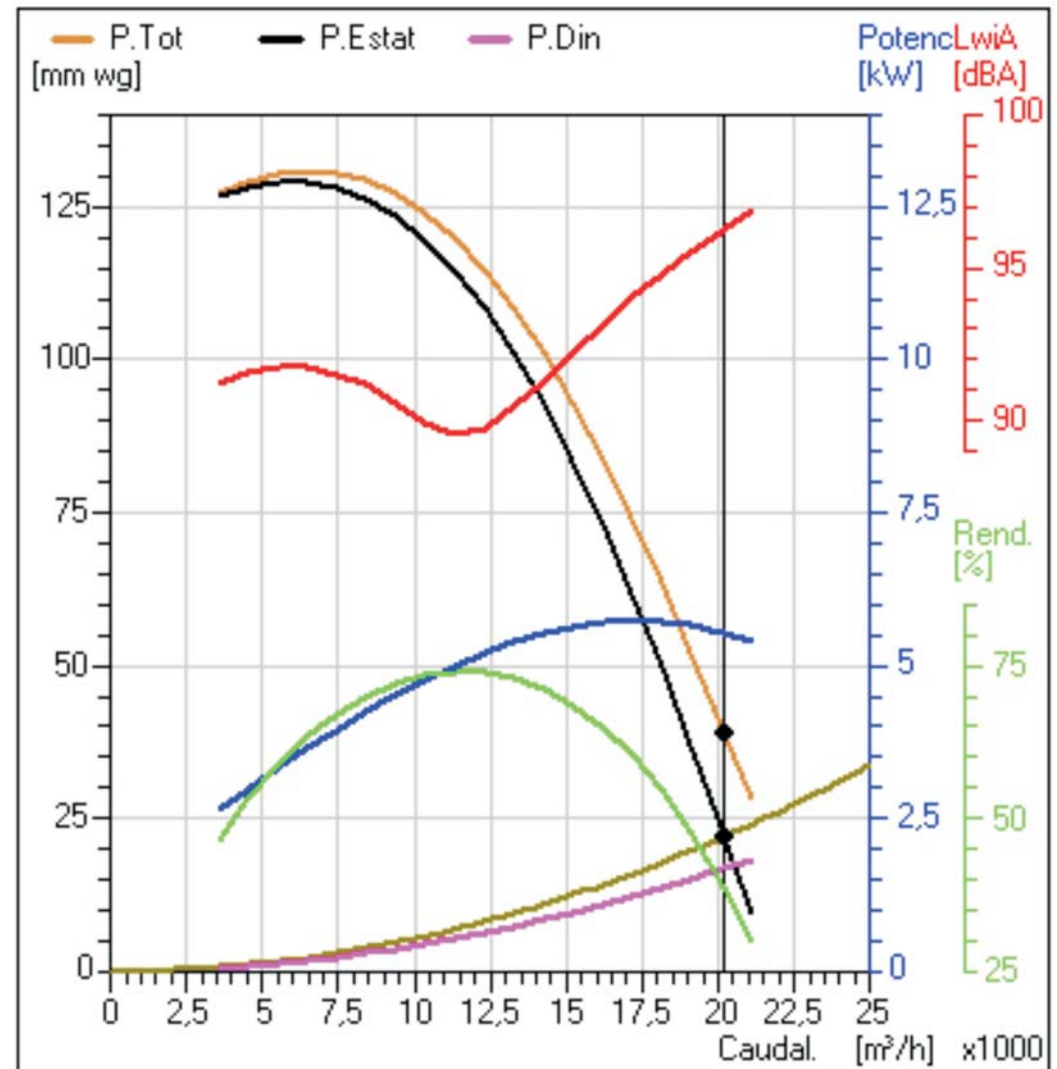



Centrífugos Mando Directo "RSH"

CURVAS DE COMPORTAMIENTO

Modelo

RSH630-6P

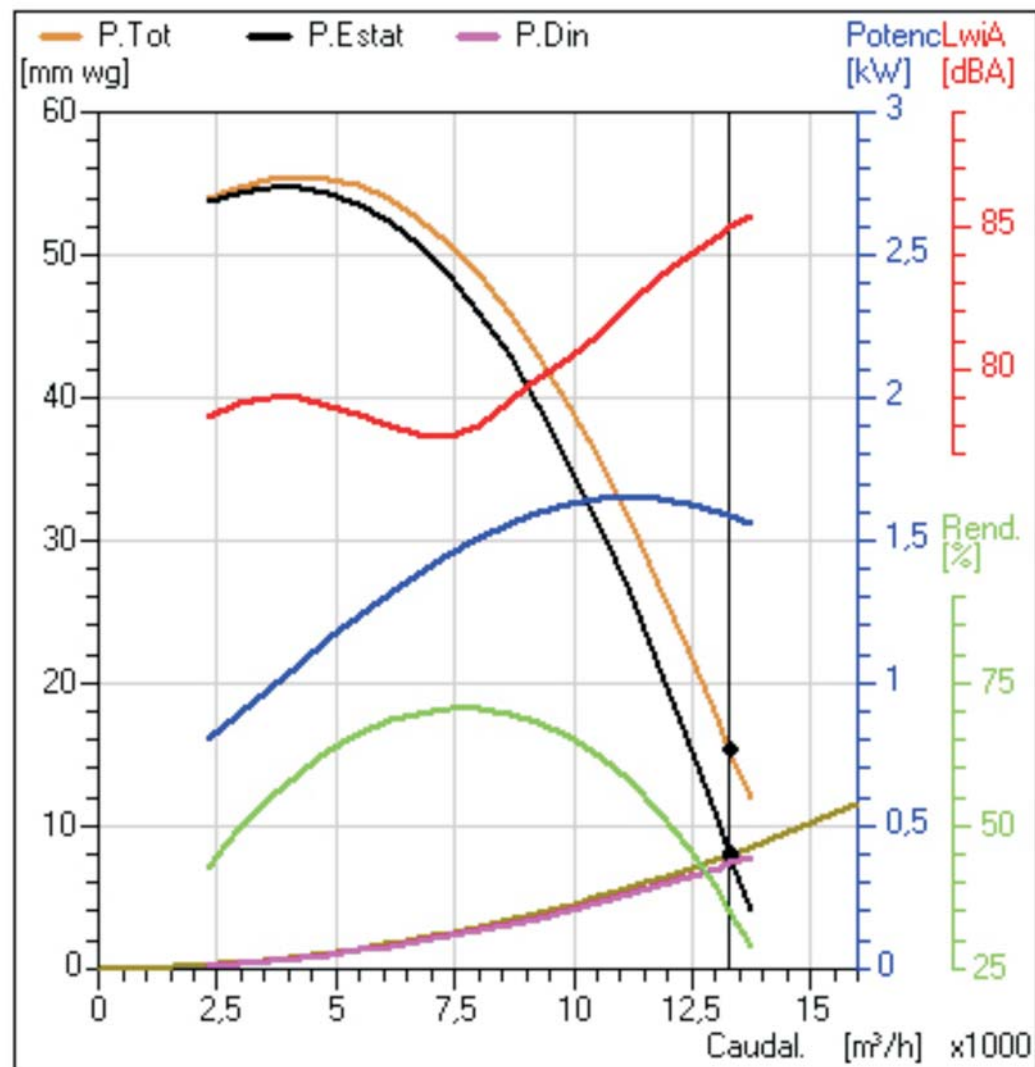



Centrífugos Mando Directo "RSH"

CURVAS DE COMPORTAMIENTO

Modelo

RSH710-4P

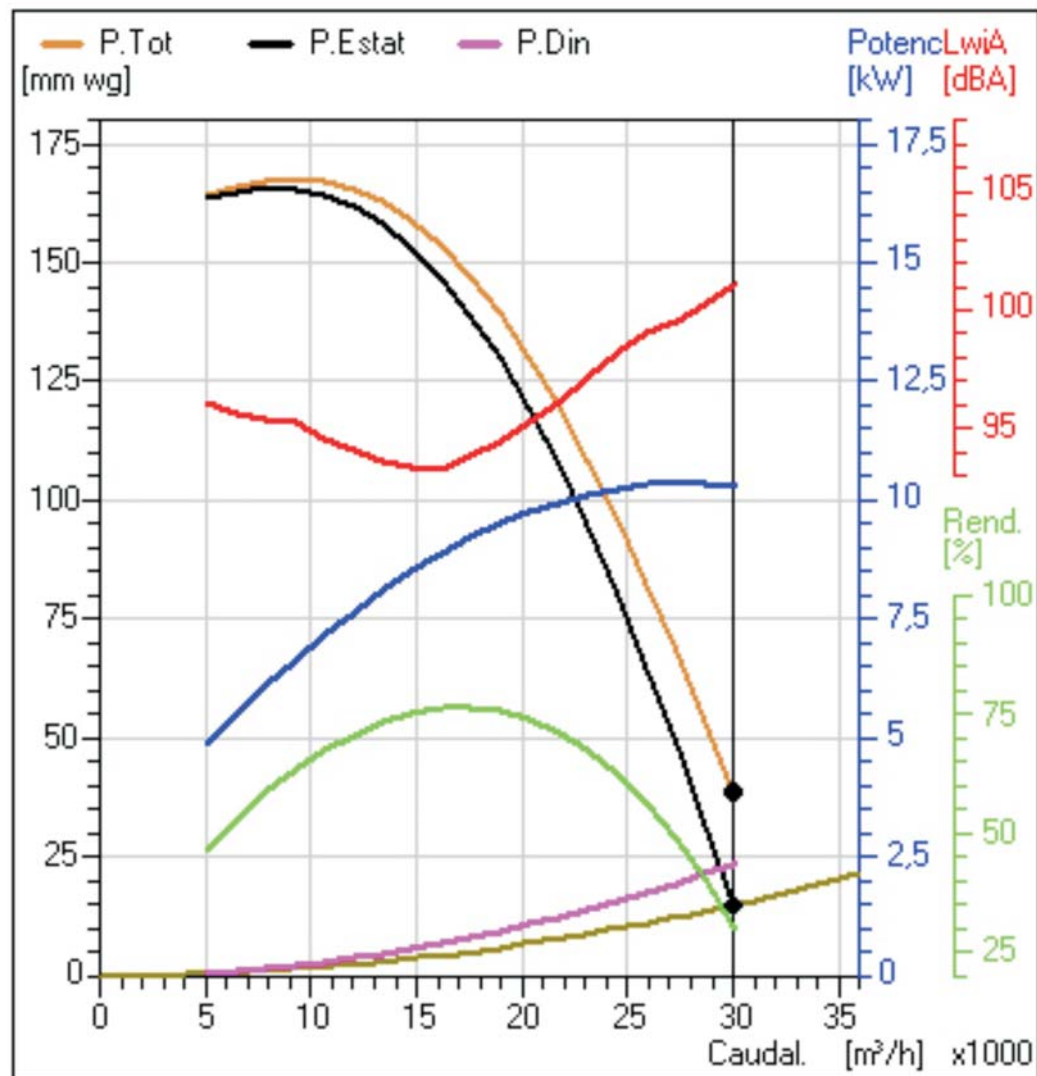



Centrífugos Mando Directo "RSH"

CURVAS DE COMPORTAMIENTO

Modelo

RSH710-6P

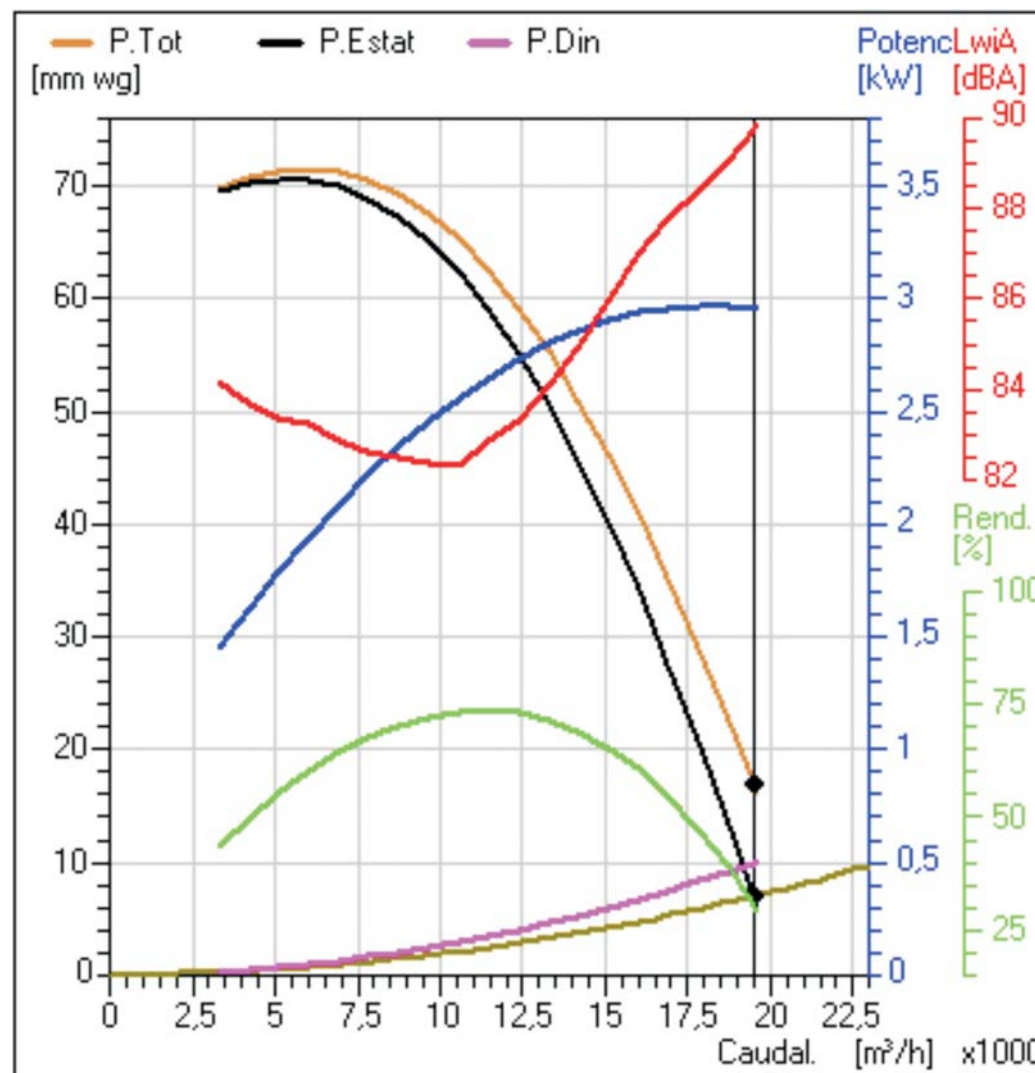



Centrífugos Mando Directo "RSH"

CURVAS DE COMPORTAMIENTO

Modelo

RSH800-6P

